

Type SX-ZX

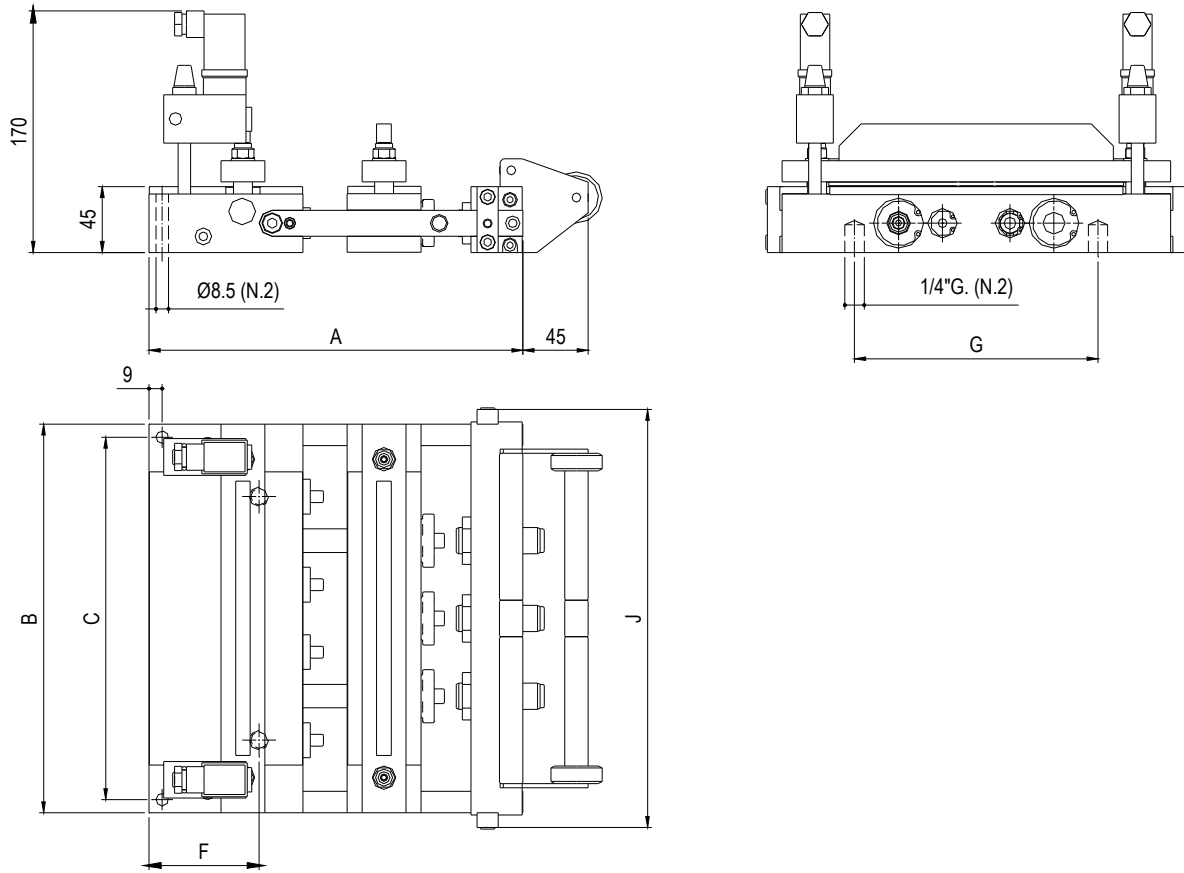

Dimensional features

TYPE	A	B	C	F	G	J
SX 50	255	265	247	75	166	285
SX 100	355	265	247	125	166	285
SX 150	455	265	247	175	166	285
SX 200	555	265	247	225	166	285
SX 250	655	265	247	275	166	285
ZX 50	255	365	347	75	146	385
ZX 100	355	365	347	125	146	385
ZX 150	455	365	347	175	146	385
ZX 200	555	365	347	225	146	385
ZX 250	655	365	347	275	146	385

Diagramma cicli/minuto

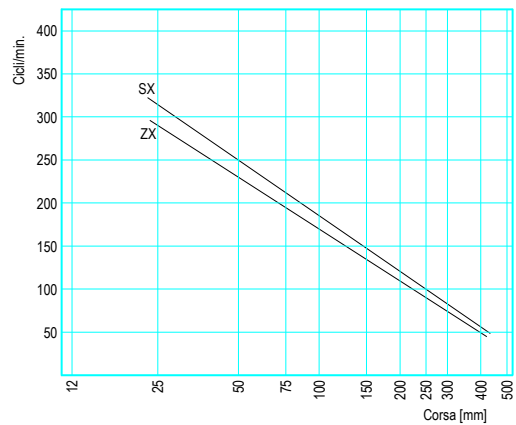

Technical features middle series type SX-ZX

Type	Max strip width [mm]	Max. stroke max. [mm]	Strip thickness [mm]	Cycles min.	Fixed clamp pressure [kg]	Mobile clamp pressure [kg]	Traction power [kg]	Air consumption (liters/min.)	Weight[kg]
SX 50	204	50	1.50	250	70	158	82	127	12.7
SX 100	204	100	1.30	180	70	158	82	180	14.9
SX 150	204	150	1.10	150	70	158	82	215	16.8
SX 200	204	200	1.00	140	70	158	82	250	18.9
SX 250	204	250	1.00	100	70	158	82	255	20.9
ZX 50	304	50	1.10	230	70	158	82	117	18.2
ZX 100	304	100	0.90	160	70	158	82	165	21.2
ZX 150	304	150	0.70	130	70	158	82	198	24.1
ZX 200	304	200	0.50	110	70	158	82	214	27.0
ZX 250	304	250	0.50	90	70	158	82	229	29.8